



6+



4



2,32m



1 = 2,46m  
2 = 1,04m  
3 = 3,01m

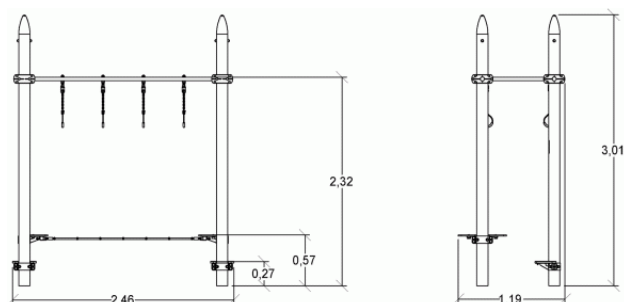

Play value :

6

balansowanie



przejście



zwisanie





## Installation of equipment

**WAŻNE:** koniecznie sprawdź instrukcję montażu dla odpowiedniego wymierzenia stref bezpieczeństwa.

———— Impact area (minimum normative surface)

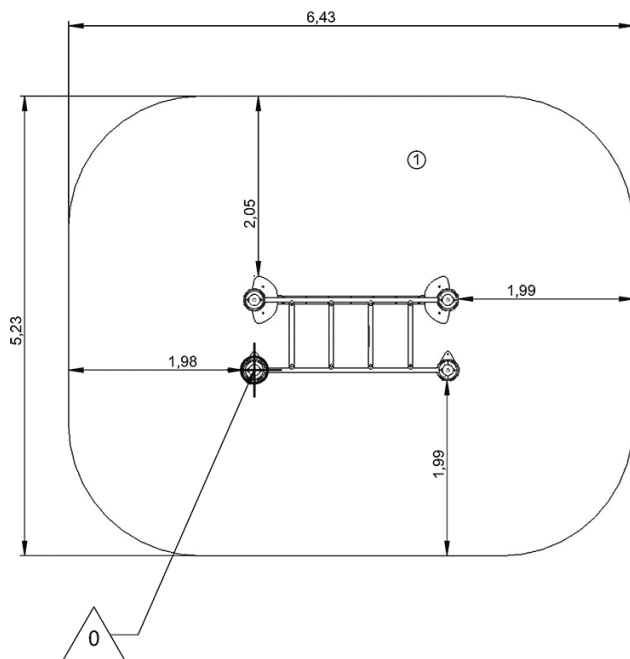
- - - - - Free space



		
1	2,32m	32m <sup>2</sup>



2



02h00



0.26m<sup>3</sup>



32m<sup>2</sup>



157kg



25kg

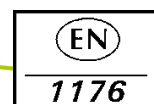



Sports formula

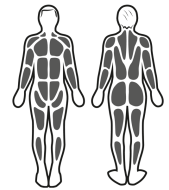

Muscular stimulation

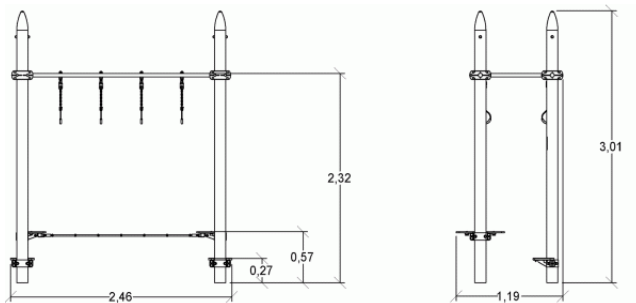

► **aktywno?ci sportowe : 6**

balansowanie



x1

przej?cie



x3

zwisanie



x2

muscle strengthening



heart health

balance



coordination

## ► Installation of equipment

WAŻNE: koniecznie sprawdź instrukcję montażu dla odpowiedniego wymierzenia stref bezpieczeństwa.

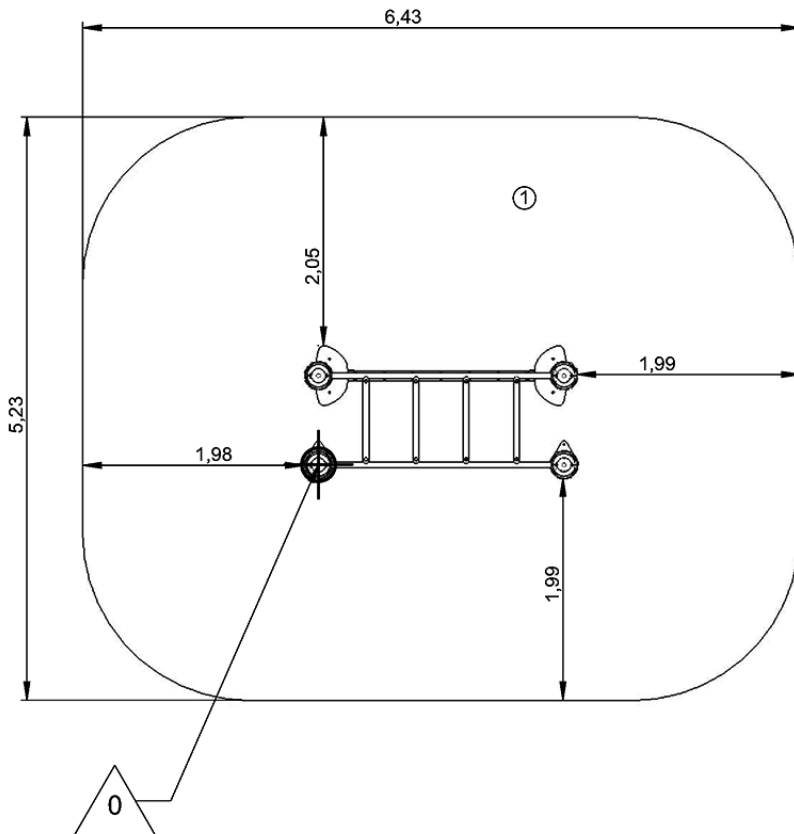
-  Impact area (minimum normative surface)
-  Free space



		
1	1,32m	21m <sup>2</sup>



2



02h00



0.26m<sup>3</sup>



32m<sup>2</sup>



157kg



25kg

